

## Brabender Bulk Bag Discharger Type BagMaster 890

The Brabender Bulk Bag Discharger Type BagMaster 890 is a discharge station for customary lined and unlined bulk bags up to 1.1 tons. In a free-standing base made of closed rectangular structural steel a horizontal massage ring is mounted, on which the bulk bag rests. Seesawing around an axis, the ring massages both the bag outlet and the bag bottom and thus ensures reliable discharge and complete emptying also of the bag corners. Dust-free connection of the bulk bag outlet is made possible by the QCD (Quick Connect Docking) system below the massage ring. The outlet is clamped manually, while the double clamping system allows separate clamping of the bag and the liner outlet. The QCD system does not need any auxiliary energy. For operation of the massage ring me-

chanism a junction box with an impulse control system and a selector switch for 3 settings (automatic, manual operation, bulk bag exchange) is mounted on the BagMaster.

The Brabender BagMaster can optionally be supplied with a built-in metering feeder. This version is also available mounted on load cells as a loss-in-weight metering feeder for continuous or batch-wise metering directly from the bag. Further options include weighed versions with evaluation units for filling level monitoring, versions with built-in cranes and explosion-proof designs. All steel parts in touch with the bulk ingredient are made of pickled and passivated stainless steel SS 1.4301 ≈ AISI 304. Mild steel parts are painted light grey as per RAL 7035. The unit conforms to CE directives.

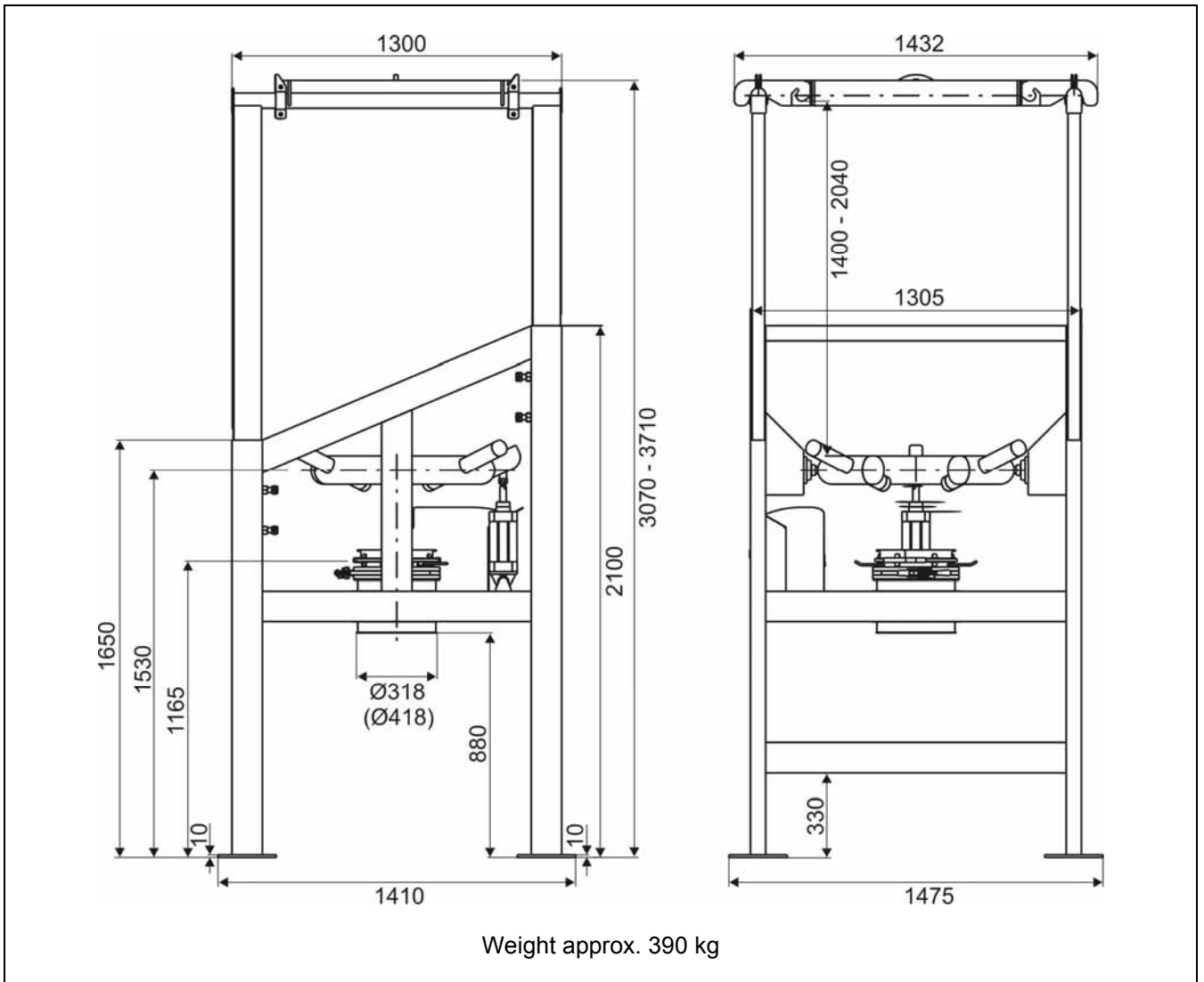

## Technical Data\*

### BagMaster Type 890

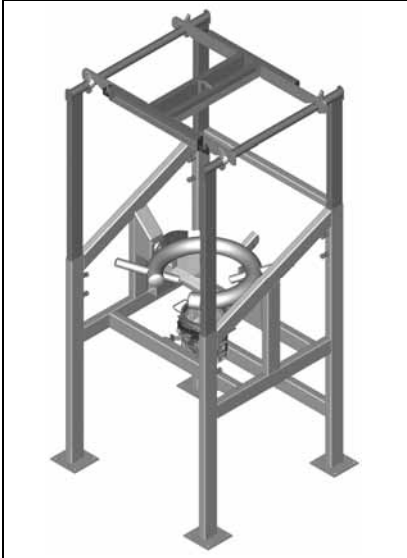

### Standard Scope of Supply

- Base (rectangular structural steel)
- Rigging frame rests adjustable in height
- Rigging frame for easy positioning of the bag in the BagMaster
- Massage ring mechanism, electro-pneumatically actuated, with junction box mounted pulse control
- Quick Connect Docking System QCD for dust-free connection of the bag respectively liner outlet

### Suitable Bag Sizes

- Bag footprint: 720 x 720 to 890 x 890 mm, outlet 320 - 520 mm Ø
- Max. filling weight 1100 kg

### Options

- Optional version equipped with a built-in metering feeder for continuous or batch-wise metering directly from the bag, also available mounted on 4 analog load cells as a loss-in-weight metering feeder in connection with the according control units (see Congrav® controller family)
- Optional version mounted on 4 analog load cells for filling level measurement incl. evaluation electronics (MS design)
- Built-in crane (K1 design)
- Explosion proofing:
  - ATEX II 3D/-- (interior/exterior)
  - ATEX II 3D/3D (interior/exterior)

### Rigging Frame



- Basic version: rigging frame with bag loop holders and single crane lug (bags hanging from crane during discharge, BagMaster in this case supplied without rigging frame rests)
- Version additionally equipped with side brackets for placement on the rigging frame rests and/or additionally with fork lift pockets
- Loading capacity up to 2 tons
- Mild steel, painted (yellow)

### Massage Ring Mechanism

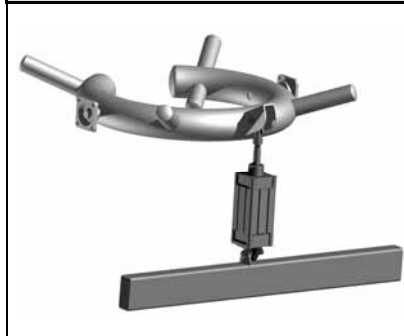

- Horizontal massage ring supporting the bulk bag with front gap allowing the bag outlet to pass through - no need to lift the bag above the ring (reduced headroom requirement)
- Seesawing by pneumatic cylinder, intervals adjustable by impulse relay
- Massage rods around ring circumference agitating the lower bag part including the bag corners
- Mild steel, painted (RAL 7035)

### Docking System QCD



- Dust-tight docking of bag and liner outlet by clamping fasteners
- Tautening by height adjustment
- Single hand-operated tensioner
- Versions: QCD 300 for bag outlets from 320 to 420 mm Ø, QCD 400 for bag outlets from 420 to 520 mm Ø (easily interchangeable)
- Parts in touch with the bulk ingredient made of stainless steel and polyurethane



**TECHNOLOGIE**

An ISO 9001/EN 29001 Certified Company

\*Modifications reserved. All data describe our products in a general manner. They are no agreement on or warranty of characteristics in the sense of § 434 or guarantee in the sense of § 443 of the German Civil Code or similar regulations and effect no liability.

Issue 2.0 (February 08)  
Supersedes 4.0 (April 07)