

Brabender Weigh-Belt Feeder Type DBW-G1-350

The Brabender Weigh-Belt Feeder Type DBW-G1-350 is a speed-controlled gravimetric feeding unit designed to feed normal to well flowing ingredients. It is distinguished by high accuracy, stable design and compact dimensions even in case of high feed rates. It can be used for continuous feeding applications, for batching and as a measuring belt feeder for continuous throughput measurement.

The weigh-belt feeder consists of a stable sheet steel casing and a built-in torsion-free cantilever belt frame with integrated weighing system. Full accessibility due to removable cover plates ensures easy cleaning and maintenance. The belt can be drawn off to the side for easy exchange.

For special cleaning requirements an easy clean variant with an extractable belt frame is available.

When ingredients are poorly flowing or floodable, the Brabender Weigh-Belt Feeder can be combined with a controlled pre-feeder.

All parts in touch with the ingredient are made of stainless steel 1.4301 (≈ AISI 304).

The exterior housing is made of rust-resistant ferritic chrome steel 1.4016 (≈ AISI 430).

The unit conforms to CE directives.

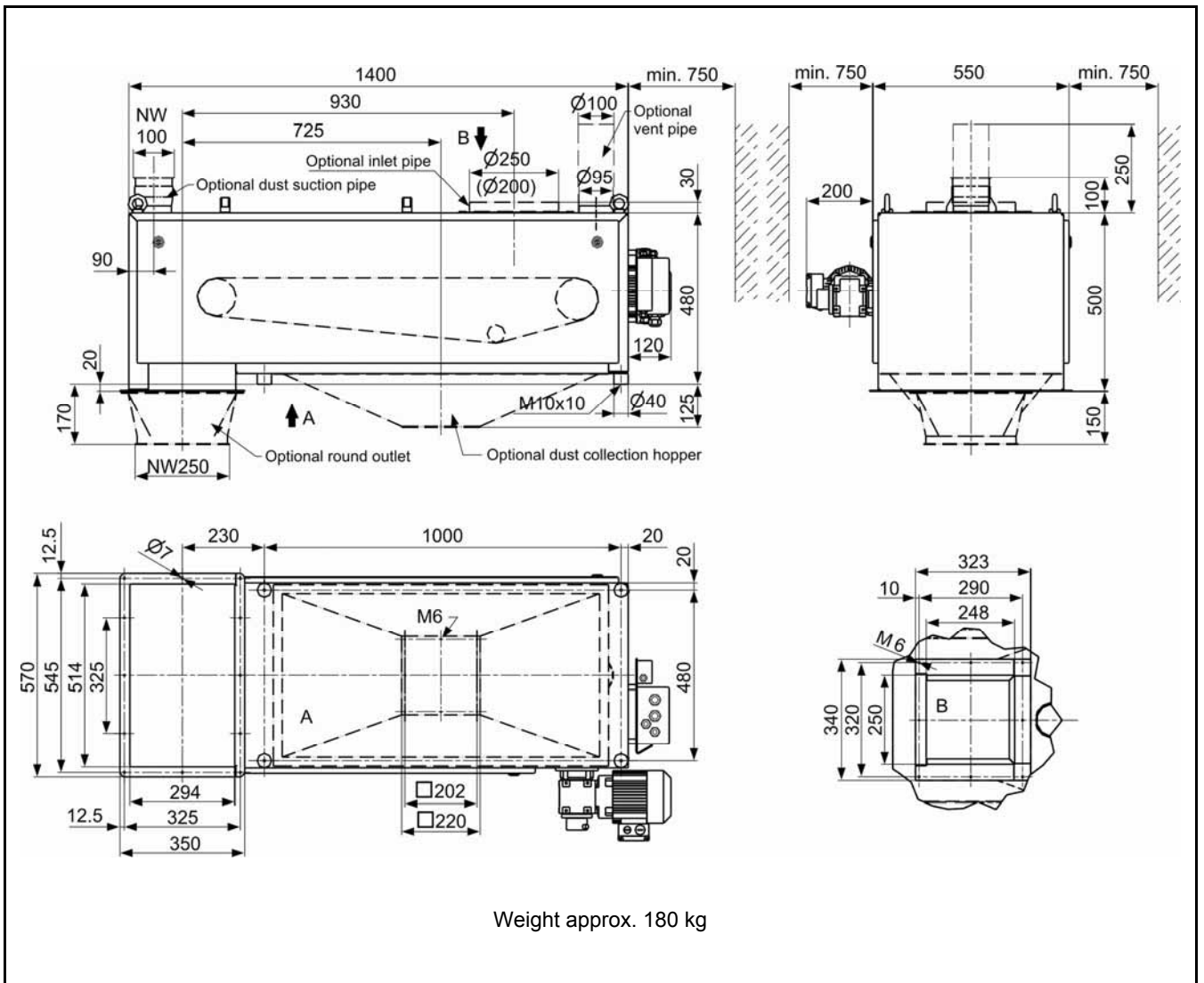

Weight approx. 180 kg

Technical Data*

Feed Rate Range

- Feed rate: 20 kg/hr - 20 t/hr (max. 20 m³/hr)
- Turndown ratio: 20:1 (100:1 with mechanical layer height adjustment)

Accuracy

- Reproducibility: $\pm 0.2 - \pm 0.5 \%$
- Linearity: $\pm 0.2 - \pm 0.5 \%$

Weighing System

- Load cell: DMS
- Protection: IP 65 (fully enclosed)
- Rated load: 5 kg
- Mechanical overload protection: 10 kg
- Operating temperature: -30°C - +70°C

Belt

- Coating: urethane (food-proof)
- Carcass: polyester fabric (endless)
- Operating temperature: -30°C - +100°C

Belt Drive

Three-phase current motor

- Wattage: 0.25 kW
- Voltage: 220-460 V
- Speed: 12-42 min⁻¹ at 50 Hz
- Protection: IP 65
- Insulation class: F

Options

- Round inlet, Ø 200 or 250 mm
- Round outlet, nominal dia 250 mm
- Flexible inlet and outlet sleeves
- Inlet shut-off valve
- Calibration valve
- Dust suction pipe (outlet side)
- Dust collection hopper
- Storage hopper
- Belt movement monitoring system (speed sensor on idle roller)
- Pressure-tight design
- Explosion-proof design (ATEX)
- Pre-feeders
- Special belt materials (silicone, nitrile, etc.)
- Stainless steel exterior housing SS 1.4301 (≈ AISI 304)
- Easy clean design with belt frame extractable to the side

Feed Controller

Microcomputer Congrav[®] for single or multi-feeder installations: see pertinent Brabender Works Standards

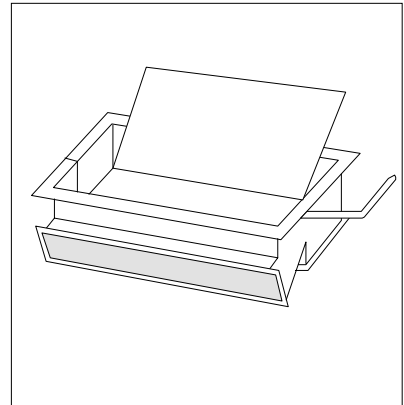

Calibration valve

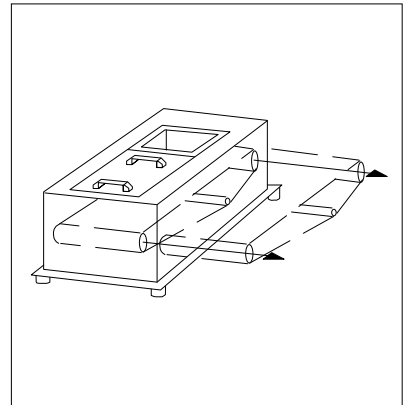

Easy clean design

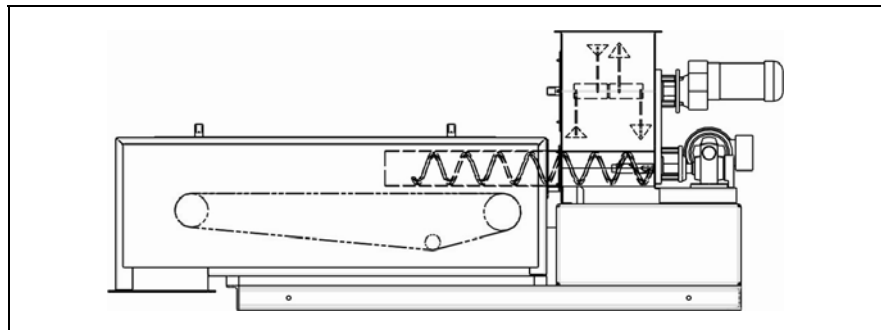

Weigh-belt feeder version with pre-feeder

brabender

TECHNOLOGIE

An ISO 9001/EN 29001 Certified Company

*Modifications reserved. All data describe our products in a general manner. They are no agreement on or warranty of characteristics in the sense of § 434 or guarantee in the sense of § 443 of the German Civil Code or similar regulations and effect no liability.

Issue 2.0 (February 08)
Supersedes 9.0 (September 07)