

Brabender Loss-in-Weight Feeder Type DDW-MD6-DVT200-200[300]

The Brabender Loss-in-Weight Feeder Type DDW-MD6-DVT200-200[300] is a special gravimetric metering feeder featuring a vibrating tray module for pellets and free flowing granular bulk ingredients.

The weigh-feeder consists of a free-standing mounting base/weighing module combination with digital load cell DigiMASS-2, a base-mounted rack with an integral storage hopper module and a vibrating tray module mounted in the rack.

The tray is vibrated by an electromagnetic vibration drive featuring a vibration amplitude feedback system, which ensures linear conveyance characteristics over the entire feed rate range. All modules are fully mounted and wired to junction boxes. Combined with a controller from the Congrav®

line they form a high-tech feed system for highest feeding accuracy.

All parts in touch with the ingredient are made of stainless steel.

Mild steel parts are painted light grey as per RAL 7035 (textured coating).

The unit conforms to CE directives.

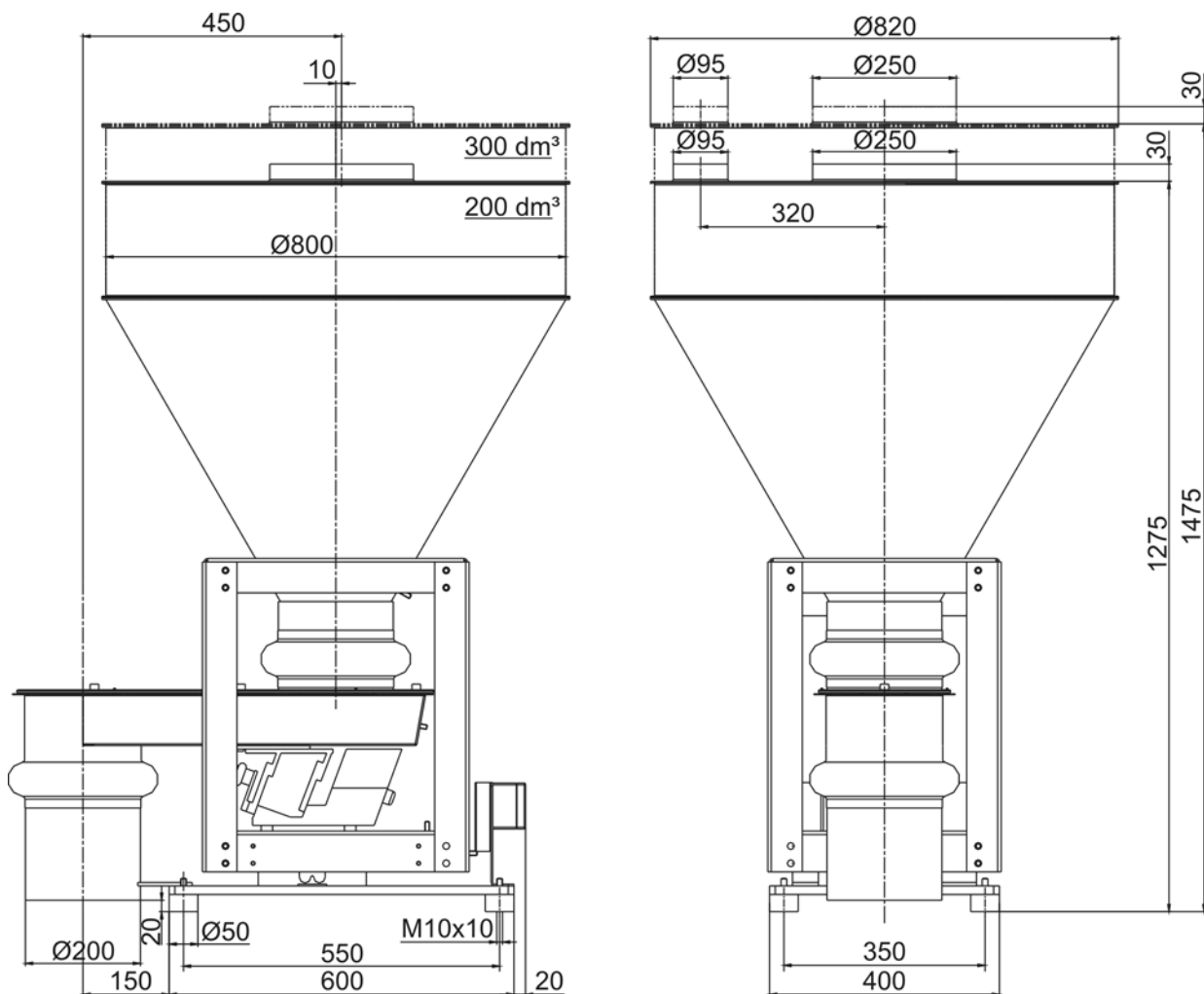

Weight with 200 dm³ hopper approx. 130 kg, with 300 dm³ hopper approx. 140 kg

Technical Data*

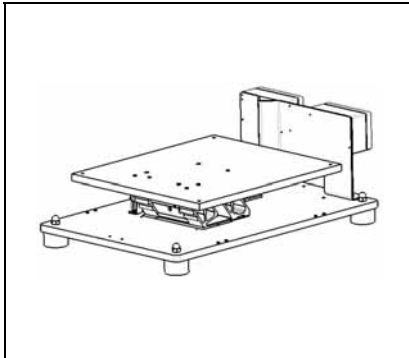

Base / Weighing Module

Mounting base/scale combination type MD6:

- Free-standing mounting base with vibration isolation pads
- Digital load cell DigiMASS-2 with two vibrating wires according to the principle of weight detection by comparison of masses
- Junction boxes

Weighing ranges:

- Version with 200 dm³ hopper:
 - 240 kg net
- Version with 300 dm³ hopper:
 - 230 kg net

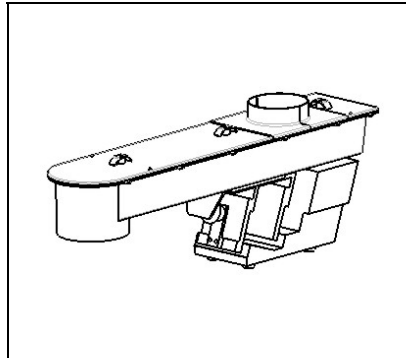

Feed Module

Vibrating tray module DVT200:

- Tray width 200 mm
- Tray cover included as standard
- Ingredient-touched parts SS 1.4301 (≈ AISI 304)
- Electromagnetic vibration drive
 - Diode voltage 156 V
 - Frequency 50 Hz
 - Enclosure protection IP 65
 - Vibration amplitude feedback

- Max. feed rate 6500 dm³/hr*
- Turndown ratio 50:1

* Feed rate at 90% of max. vibration drive capacity (reserve capacity required for regulation in gravimetric metering already taken into consideration).

Feed rate data refer to the following reference medium: plastic pellets, free flowing, bulk density 0.5 kg/dm³, grain size 4 mm

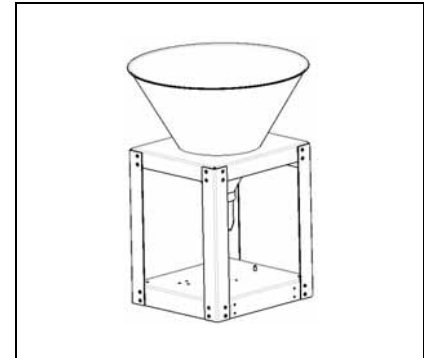

Rack / Hopper Modules

- Conical hopper module as an integral part of the rack in which the feed module is mounted
- Cover module with inlet pipe and vent pipe for automatic refilling
- Ingredient-touched parts SS 1.4301 (≈ AISI 304)

Hopper volumes:

- 200 dm³
 - 300 dm³
- (suited to feed rate range)

Accessories / Options

- Flexible connection sleeves
- Dust filter cartridge for vent pipe
- Safety grid, SS 1.4301 (≈ AISI 304)

Special Designs

- Pressure-tight design
- Pressure compensation on inlet pipe
- Pressure compensation on outlet pipe
- Explosion-proof design

Control Modules

Congrav[®] operating and control units incl. vibration controller for control cabinet installation or Congrav[®] operating unit and feeder-mounted control modules "ISC"

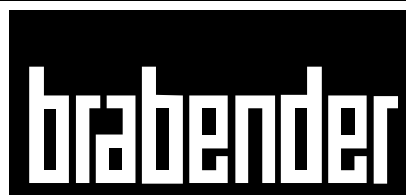

TECHNOLOGIE
An ISO 9001/EN 29001 Certified Company

*Modifications reserved. All data describe our products in a general manner. They are no agreement on or warranty of characteristics in the sense of § 434 or guarantee in the sense of § 443 of the German Civil Code or similar regulations and effect no liability.

Issue 3.0 (March 11)
Supersedes 2.0 (February 08)