

Loss-in-Weight Scale Type DDW-MD1-MT-1(2)[3] with Brabender MiniTwin Feeder

The Brabender MiniTwin Feeder from the Brabender Lab Line is one of the smallest twin-screw feeders in the world and feeds powders down to a minimum feed rate of a few grams per hour due to screw profiles of no more than 12 mm in diameter. Especially when fine powders are fed at ultra-low rates, the self-cleaning twin concave screws offer particularly brilliant dispense without pulsations. Due to its low dimensions and its low center of gravity the Brabender MiniTwin Feeder permits combination with a platform scale allowing full access to the feeder from all sides. The platform scale and the Brabender MiniTwin Feeder together form a high-tech gravimetric loss-in-weight feeder in laboratory size. For weighing the system uses the digi-

tal load cell DigiMASS-2 in platform scale design featuring two vibrating wires and real weight determination by comparison of masses. The system offers utmost reproducibility, linearity and long-term stability. All parts in touch with the ingredient are made of stainless steel. The unit conforms to CE standard.

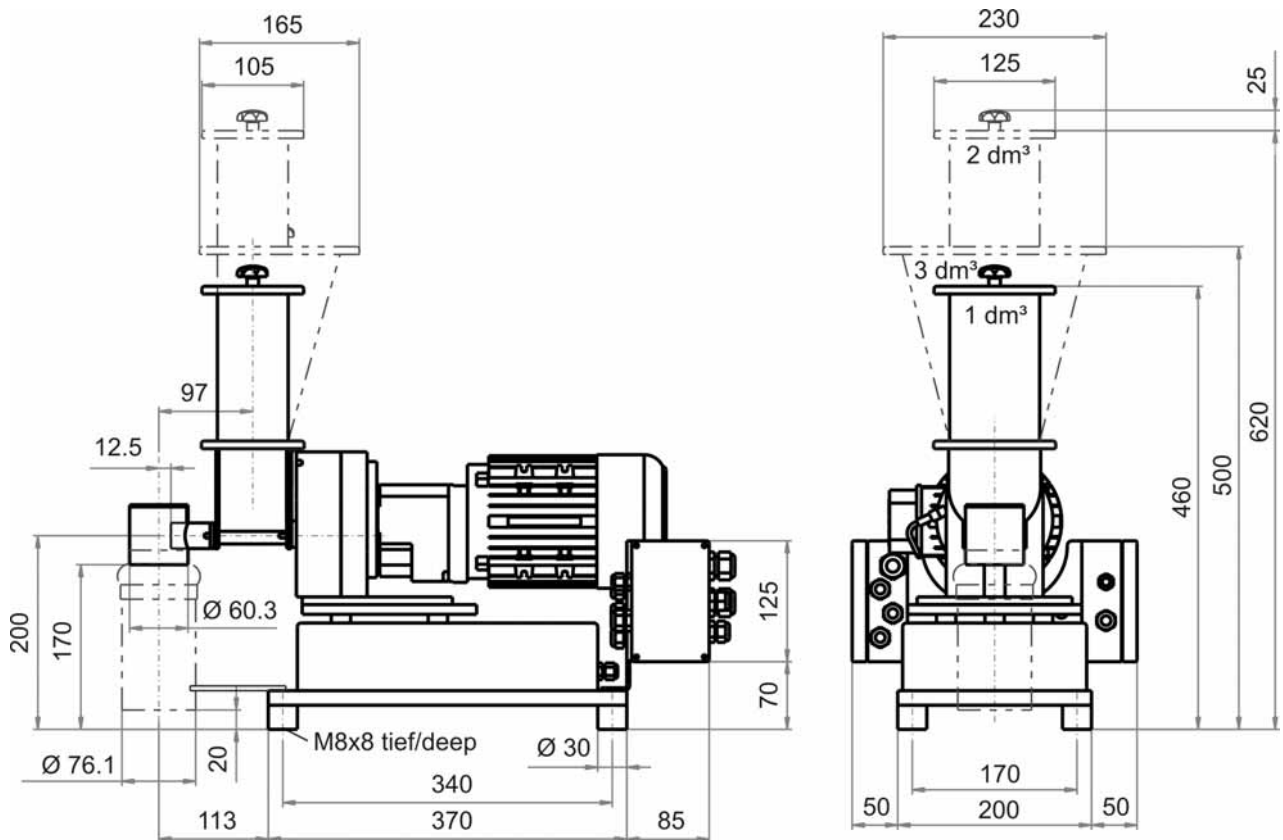
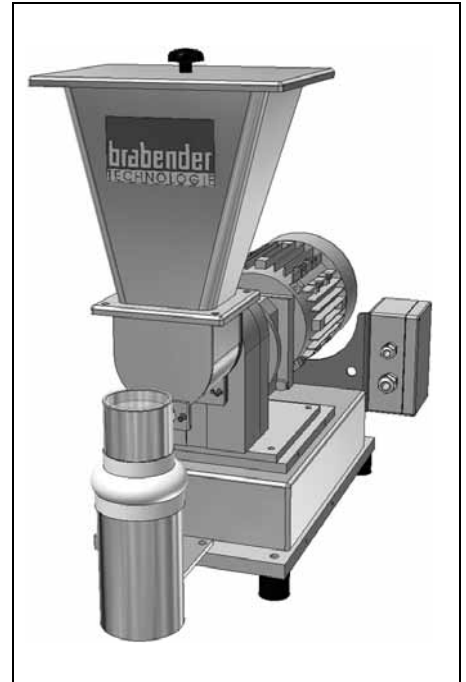

Weight with 1 dm³ extension hopper approx. 22 kg, 2 dm³ hopper approx. 22.5 kg, 3 dm³ hopper approx. 23 kg

Technical Data*

Available Screw Sizes and Feed Rates

Screw Type Ø mm x p mm	Tube Designation	Tube Dia. mm	Speed r.p.m.	Max. Feed Rate dm ³ /hr*
Twin Concave Screw TC 12/04	130 T	16 x 1.5	200 (107**) / 100 Hz	1.8 (1.0**)
TC 12/12	130 T	16 x 1.5	200 (107**) / 100 Hz	8.0 (4.3**)

* The max. feed rates mentioned above are theoretical values based on a screw filling level and a motor speed of 100 % each. Depending on the ingredient flow characteristics the screw filling level may decrease down to 50 %. In gravimetric application further feed rate reductions have to be taken into account because part of the upper motor speed range is required to balance bulk density variations.

** Values in brackets refer to feeders with optional 23 r.p.m. drive motors

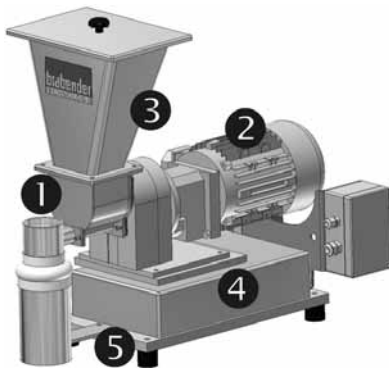

Component Groups

- ❶ Twin-screw feed module
- ❷ Maintenance-free 3-phase motor
- ❸ Stainless steel extension hopper, 1, 2 or 3 dm³, incl. safety grid
- ❹ Weighing system MD1 with digital load cell DigiMASS-2
- ❺ Aluminum base plate with anti-vibration pads

Digital Weighing System

Weighing module MD1 (platform scale) with digital load cell DigiMASS-2:

- Principle of two vibrating wires

- Real comparison of masses
- Stabilization of physical ambient interferences (temperature variations, shocks) due to principle of two wires
- Software filter for dynamic electronic vibration attenuation
- High speed data communications due to serial interface
- Theoretically utilizable resolution of 4,000,000 d
- High electromagnetic compatibility

Weighing Range

- 6.0 kg net with 1 dm³ ext. hopper
- 5.5 kg net with 2 dm³ ext. hopper
- 5.0 kg net with 3 dm³ ext. hopper

Three-Phase Current Motor

- Wattage: 0.09 kW
- Voltage: 230/400 V
- Speed: 43 (optional 23) r.p.m.
- Enclosure protection IP 55
- Insulation class F

Materials

- Steel parts in touch with the in-

gredient made of stainless steel SS 1.4301 ≈ AISI 304 except for the twin concave screws (stainless steel SS 1.4305 ≈ AISI 303)

Accessories / Options

- Laid-on cover with handle
- Motor with lower output speed
- Mass plate to eliminate vibration
- Version without scale system for volumetric metering (see Brabender Works Standard „Brabender MiniTwin Feeder Type MT“)

Controls

- Congrav[®] control and operating modules with speed controller type FC-V1.1 for control cabinet installation (see the according Brabender Works Standards)
- Alternatively Congrav[®] operating modules with "ISC" control and regulation modules in the Brabender SCC (Single Cable Connection) field bus system (see the according Brabender Works Standards)

brabender

TECHNOLOGIE

An ISO 9001/EN 29001 Certified Company

*Modifications reserved. All data describe our products in a general manner. They are no agreement on or warranty of characteristics in the sense of § 434 or guarantee in the sense of § 443 of the German Civil Code or similar regulations and effect no liability.

Issue 6.0 (June 10)
Supersedes 2.0 (February 08)