

Brabender MicroBatch Scale Type MB-50

The Brabender MicroBatch Scale is a small-size scale for automatic batching of small ingredient amounts according to the gain-in-weight principle. The central unit of the scale is a weighed bowl, which automatically tilts over after completion of the batch and discharges its contents. The 360° turn and the semispherical shape ensure complete discharge without residues.

The Brabender MicroBatch Scale is suitable for all flowable bulk ingredients, particularly with poor flow characteristics, and can be combined with all kinds of feeding devices. High accuracy is achieved by using coarse-fine flow feeding or "A.R.T." mode (= Automatic Rate Turndown) with total speed control over the whole turndown range.

Here, feeder speeds are run down in a curve function from a "turndown" point automatically computed by the Congrav® microcomputer controller pertinent to the scale to the switch-off point also autocomputed by the controller, thus achieving even better accuracy. The feeders are fully controlled by the microcomputer controller.

Complete single or multiple ingredient batching stations with Brabender feeders and common support structures are available as well as versions without controllers with special interfaces for integration in OEM systems.

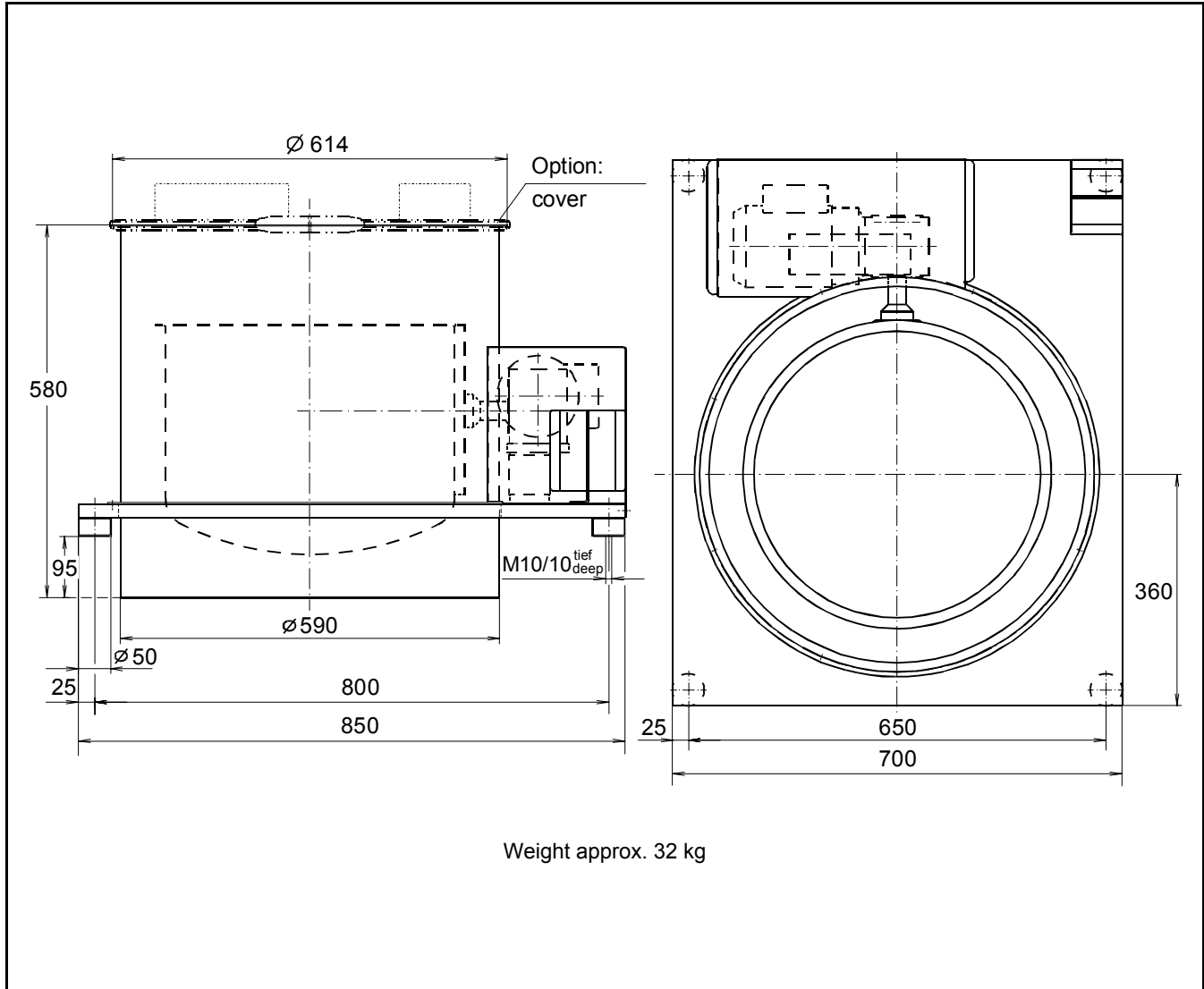
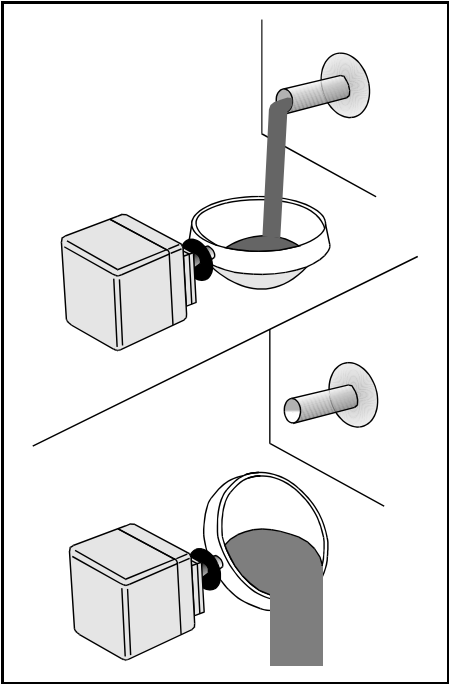

Technical Data*

Configuration examples: Brabender MicroBatch Scale with feeders

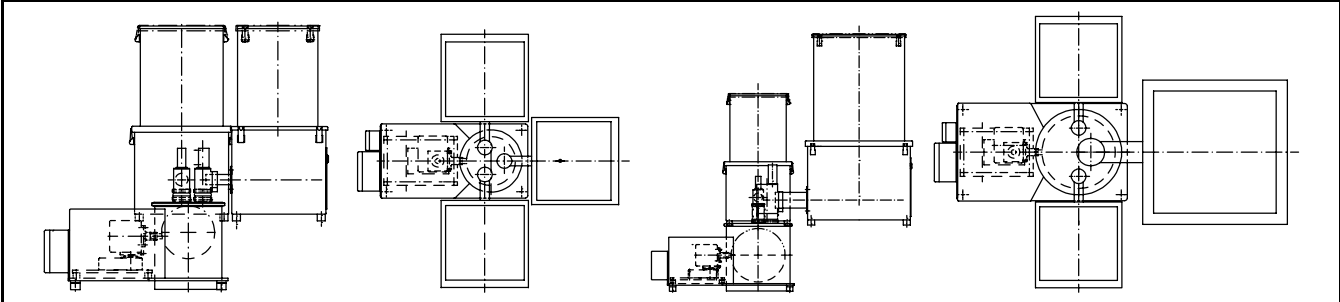

Component Groups

- Stainless steel base plate with vibration isolation pads
- Brabender weighing system
- Tilt-over weighing bowl, volume 50 dm³, tilting range 360°
- A. C. tilting drive with maintenance-free worm gearing
- Stainless steel cover for weighing system and tilting drive
- Junction boxes
- Stainless steel downpipe around the weighing bowl

Design: completely assembled and wired to junction boxes

Accessories

- Cover for downpipe with inlet pipes (number and arrangement dependent on upstream feeders) and vent pipe
- Flexible sleeves for inlet pipe, vent pipe and outlet
- Double blade valve for the downpipe for dust-tight sealing
- Brabender feeders, e. g.
 - Brabender FlexWall® Feeder
 - Brabender Screw Feeders
 - Brabender Twin-Screw Feeders
 - others (see the respective Brabender Works Standards)

- Pneumatic quick-closing valves for outlets of Brabender feeders

Tilting Drive

A.C. Synchronous Motor
 Power input: 120 W
 Voltage: 220-460 V, 50-60 Hz
 Protection: IP 65
 Insulation class F

Weighing System

Brabender weighing system
 Weighing ranges optionally

- 30 kg net
- 55 kg net

Materials

- Steel parts of basic version and accessories in touch with ingredient made of SS 1.4301 (≈ AISI 304), weighing bowl optionally teflonized

Control

Microcomputer controller Congrav® for feeder control in coarse-fine flow or, with continuously controllable feeders, over the whole turndown range in A.R.T. mode (Automatic Rate Turndown)

Coarse-fine flow:

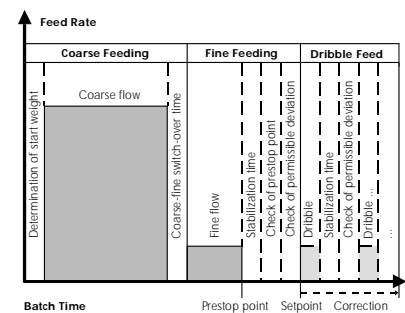

A.R.T. method:

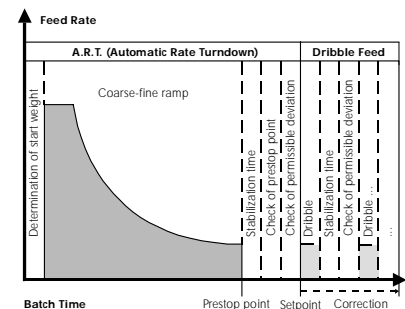

Options

- Complete single and multiple ingredient batching stations incl. Brabender feeders and support structures
- Versions without controllers with special interfaces for integration in OEM systems
- Special discharge aids
- Calibration system



An ISO 9001/EN 29001 Certified Company

*Modifications reserved. All data describe our products in a general manner. They are no agreement on or warranty of characteristics in the sense of § 434 or guarantee in the sense of § 443 of the German Civil Code or similar regulations and effect no liability.

Issue 2.0 (February 08)
 Supersedes 3.0 (March 01)