

# Brabender Operating Panel Congrav® OP 12 Touch for multiple feeder control systems with ISC-CM plus

The Brabender touch screen operating panel Congrav® OP 12 Touch serves for operation of up to 16 gravimetric Brabender metering feeders (loss-in-weight feeders, weigh-belt feeders, etc.) with feeder-mounted control and speed control modules ISC-CM plus / ISC-FC plus ("Intelligent Signal Conditioner") in multiple feeder control systems. Here, the Congrav® OP 12 Touch can be used both as a central operating unit in the Brabender SCC Field Bus System (SCC = Single Cable Connection) and in connection with a customer's central automation system (host/PLC) as a local operating panel in Ethernet or field bus configurations where its broad variety of optional interfaces allows interfacing with almost any automation system applied. The Congrav® OP 12 Touch operating

panel has a graphic display/user surface with a virtual keypad allowing extraordinarily easy operation due to language-independent and self-explaining touch-sensitive input fields on a huge touch screen (12.1" color display). Based on the operating system Microsoft® Windows®, the display allows intuitive operation and observation of the feeding process. As a result, operator training time and the risk of faulty operation are reduced to a minimum. The unit conforms to CE directives and is distinguished by its high electromagnetic compatibility.

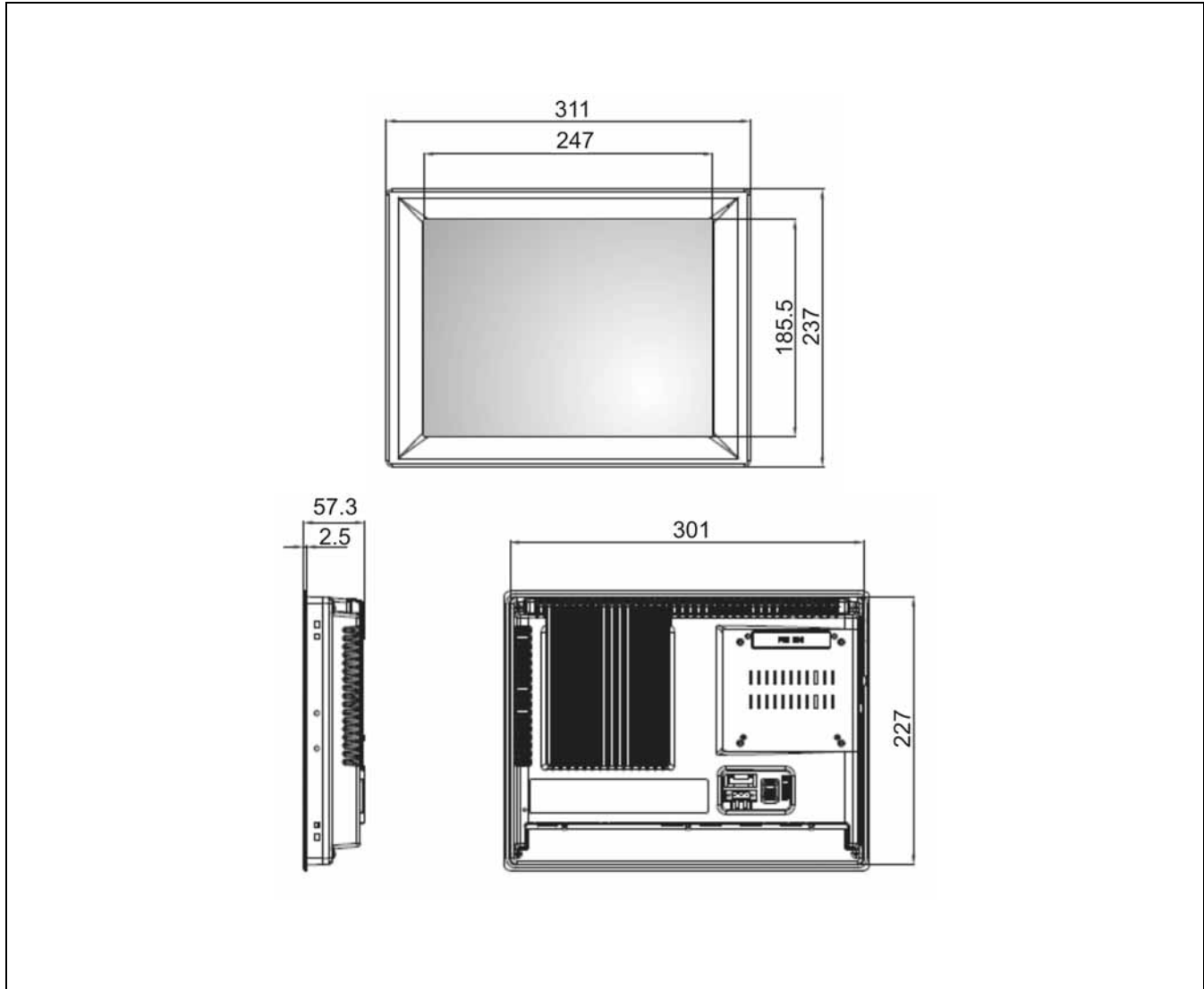

## Technical Data\*

### Brabender Multiple Feeder Control Systems with Operating Panel Congrav® OP12 Touch

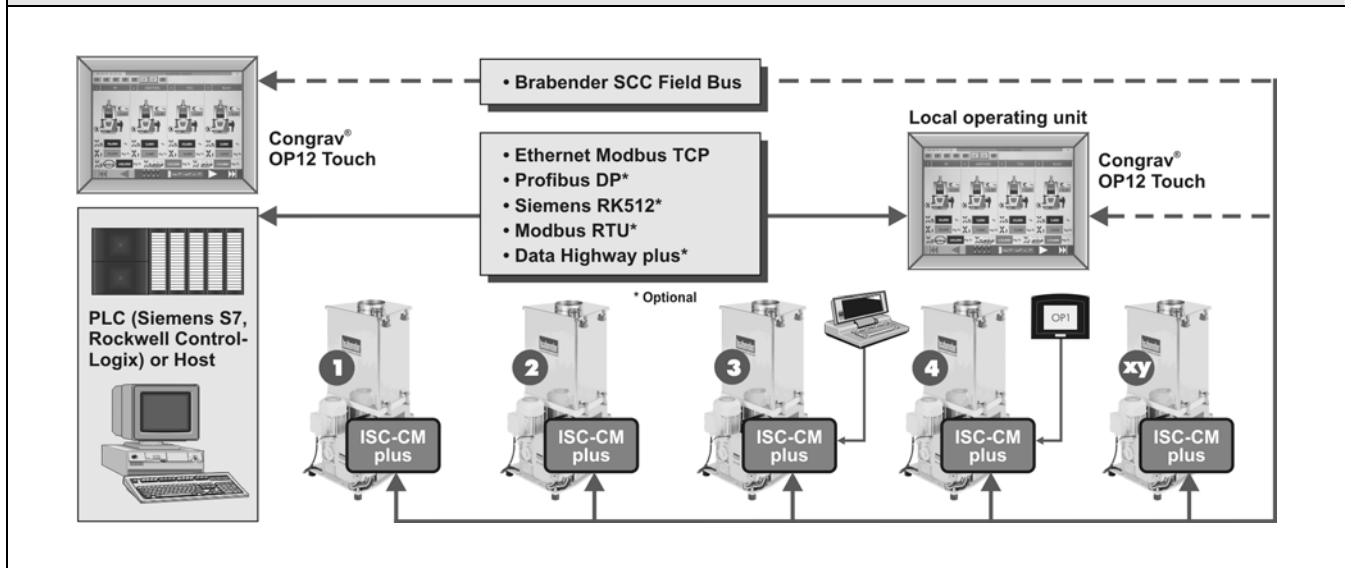

#### Application

- Touch screen operating panel for multiple feeder control systems
- Allows to connect max. 16 "intelligent" Brabender weigh feeders with feeder-mounted control/speed control modules ISC-CM/FC plus (see Works Standard "ISC-CM/FC plus") in field bus interconnection (integration of volumetric feeders with variable speed motors possible)
- Applicable as a central operating panel (Brabender SCC Field Bus System)
- Alternatively applicable as a local operating panel interfaced with an automation system on site (host/PLC)

#### Design

- Touch screen panel for control cabinet installation, also suitable for desk top placement and wall mounting (vertical position only)

- 12.1" backlit color display (touch screen)
- Graphic user surface
- Virtual keypad on the display
- Mounting depth 70 mm (plus approx. 100 mm clearance for air circulation)
- Cabinet cutout 302.5 x 228.5 mm
- Front framing: Al-Mg
- Rear housing: diecast aluminium
- Enclosure protection: housing IP 30, front IP 65
- Weight approx. 3.5 kg
- Supply voltage 18-32 VDC
- Ambient temperature 0-45°C, max. 85% air humidity without condensation

#### Interfaces

- 1 x RS 485 for single cable connection of max. 16 "intelligent" Brabender weigh feeders (loss-in-weight feeders, weigh-belt feeders, etc.) with feeder-mounted control and speed control modules ISC-CM plus / ISC-FC plus

- 1 x Ethernet Open Modbus TCP for connection to customers' automation systems (host/PLC)

#### Options

Alternative host/PLC interfaces:

- Profibus DP
- Siemens RK 512
- Modbus RTU
- Data Highway plus

Extension modules (I/O modules) for top hat rail mounting (communications via Brabender I/O Bus):

- Digital module: 4 digital inputs (e. g. start, stop, alarm reset, etc.), 4 digital outputs (e. g. run, alarm, etc.)
- Analog module: 2 analog inputs 0(2)-10 V (e. g. analog control signal), 2 analog outputs 0(4)-20 mA (e. g. actual value)

# brabender

## TECHNOLOGIE

An ISO 9001/EN 29001 Certified Company

\*Modifications reserved. All data describe our products in a general manner. They are no agreement on or warranty of characteristics in the sense of § 434 or guarantee in the sense of § 443 of the German Civil Code or similar regulations and effect no liability.

Issue 3.0 (March 11)  
Supersedes 1.0 (January 11)