



Screw Feeder

DDSR40B

Volumetric and Gravimetric



General Information

The [DDSR40B](#) feeder is ideal for difficult flowing, sticky or floodable bulk ingredients that tend to compact or form bridges.

The feeder has the following main components: A stainless steel screw trough, an agitator in the screw trough, a 3 phase [motor](#) as agitator drive, a twin screw and tube, a 3 phase [motor](#) as screw drive and an extension hopper with volumes of 100 dm³ (3.5 cuft) or 200 dm³ (7 cuft).

The horizontal agitator works to consistently fill the screw and prevents hopper bridging while providing mass flow. In addition, the screw trough has a large cross-sectional area which when combined with a steep walled hopper naturally promotes ingredient flow.

This results in optimal feeder accuracy and control.

The [DDSR40B](#) is easily disassembled for wet or dry cleaning. All services can be from the front or back.

The gravimetric version includes the [weighing system](#) DLS6 and MD6 featuring a high-resolution digital load cell with serial data transmission as well as MS6 with strain gauge load cell with advanced filtering technology.

The unit conforms to CE directives.

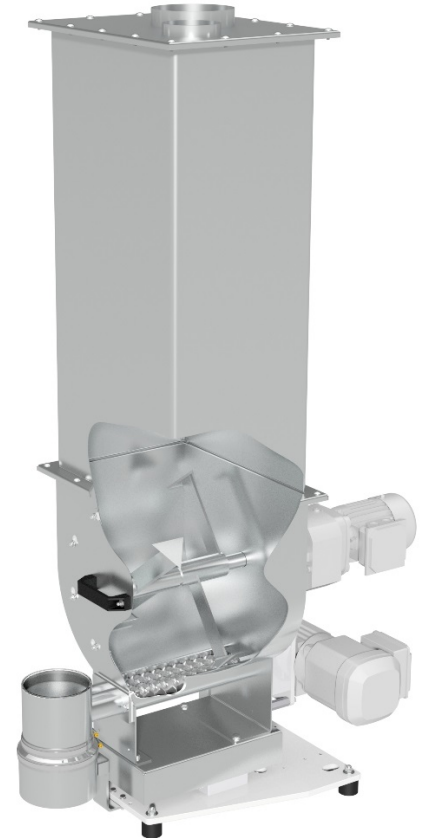

Model Specification

Screw drive	Three-phase motor
Drive power	0.37 kW (0.5 HP)
Screw speed	385 min ⁻¹
Screw speed optional	-
Trough agitator	yes
Agitator drive	Three-phase motor
Drive power	0.12 kW (0.16 HP)



Control Modules

Control and speed modules are offered either mounted onto the feeder ([Congrav® CM-E](#)) or are available for mounting in a separate control panel ([Congrav® CB-E](#) or [Congrav® CB-S](#)).

Controls can communicate directly to most host/ PLC systems or to Brabender Technologie Congrav® Operator Interfaces.

Technical Drawings and Dimensions

	volumetric feeders	gravimetric feeders	
		Control module CB	Control module CM
100 dm ³ (3.5 cuft) Hopper	DDSR40B-100Q	DDW-DLS(MD)[S]6-DDSR40B-100Q	DDW-DLS(MD)[S]6-DDSR40B-100Q CM
200 dm ³ (7 cuft) Hopper	DDSR40B-200	DDW-DLS(MD)[S]6-DDSR40B-200	DDW-DLS(MD)[S]6-DDSR40B-200 CM



Screw Feeder

DDSR40B

Volumetric and Gravimetric



Screw Sizes and Feed Rates

Screw type	Designation Ø / p [mm]	Tube designation	Tube dia. [mm]	Max. speed [min ⁻¹]	Max. feed rate * [dm ³ /h]	Max. feed rate* [cuft/hr]
Double Spiral Screw (SS)	SS 33/22	419	48.3x3.2	385 / 100Hz	800	28.3
	SS 33/22	470	53.0x3.0	385 / 100Hz	1208	42.7
	SS 33/35	419	48.3x3.2	385 / 100Hz	1311	46.3
	SS 33/35	470	53.0x3.0	385 / 100Hz	1960	69
Twin-spiral Screw (TS)	TS 40/27	419	48.3x3.2	385 / 100Hz	1384	48.9
	TS 40/27	470	53.0x3.0	385 / 100Hz	1671	59
	TS 40/42	419	48.3x3.2	385 / 100Hz	2247	79
	TS 40/42	470	53.0x3.0	385 / 100Hz	2693	95
Twin-blade Screw (TB)	TB 40/28	419	48.3x3.2	385 / 100Hz	1141	40
	TB 40/43	419	48.3x3.2	385 / 100Hz	1853	65
Twin-concave Screw (TC)	TC 40/12	419	48.3x3.2	385 / 100Hz	150	5.3
	TC 40/23	419	48.3x3.2	385 / 100Hz	288	10.2
	TC 40/27	470	53.0x3.0	385 / 100Hz	686	24.2
	TC 40/50	470	53.0x3.0	385 / 100Hz	1604	59.7

* Theoretical values at 100% screw filling level and motor speed. Depending on the flow characteristics the screw filling level may decrease to 50%. Further limitations have to be considered for gravimetric feeding, as max. speed should be reduced to allow for bulk density variations.

Technical Specification

Ambient temperature:	0°C to +45°C (32°F to 113°F)
Humidity of the air:	up to 85% without condensation
max. vacuum/pressure :	3 hPa (3 mbar) (1.2 Inches of water)
Product temperature:	0°C to +60°C (32°F to 140°F)
max. bulk density (volumetric):	1.5 kg/dm ³ (94 lb/cuft)
max. bulk density (with DLS6 and MD6):	1.5 kg/dm ³ (94 lb/cuft) * with hopper 100 dm ³ (3.5 cuft)
	1.2 kg/dm ³ (75 lb/cuft) * with hopper 200 dm ³ (7 cuft)
max. bulk density (with MS6):	1.5 kg/dm ³ (94 lb/cuft) * with hopper 100 dm ³ (3.5 cuft)
	1.1 kg/dm ³ (69 lb/cuft) * with hopper 200 dm ³ (7 cuft)
Screw trough, extension hopper, hopper lid:	1.4301 (304 SS)
Screws, screw tubes, outlets:	1.4571 (316 SS), 1.4301 (304 SS) or polyurethane, food-proof acc. to LMBG*
Non-contact components:	Aluminum, plated or painted steel (RAL 7035)
Extension hopper 100 dm³ (3.5 cuft) or 200 dm³ (7.1 cuft)	Hopper lid for automatic refill or manuel refilling
Screw drive:	0.37 kW (1/2 HP), IP65; ISO class F; TEFC; frequency-controlled
Agitator drive:	0.12 kW (0.16 HP), IP65; ISO class F; TEFC; frequency-controlled
Power supply:	AC 230/400V **(110VAC/1PH/60hz, 230/460VAC/3PH/60 hz)
Net weighing range DLS6 and MD6:	246 kg (542 lb) with hopper 100 dm ³ (3.5 cuft)
	234 kg (516 lb) with hopper 200 dm ³ (7 cuft)
Net weighing range MS6:	216 kg (476 lb) with hopper 100 dm ³ (3.5 cuft)
	204 kg (450 lb) with hopper 200 dm ³ (7 cuft)
* other values upon request	** 3 phase motors are designed for a power supply of: 230/400 V, 50 (60) Hz, and for the operation in TT networks, TN networks or networks with earthed neutral conductor. For different networks adaptation measures are necessary.

Options and Accessories

- Flexible [inlet and vent connections](#)
- Flexible [outlet connections](#)
- Interchangeable screws and screw tubes
- [DESTACO clamp fasteners](#) with safety switch
- Versions for higher and lower temperatures
- [Explosion-proof executions](#) as per directive 2014/34/EU (ATEX) or NFPA
- Vertical outlet with [quick release](#)
- [Maintenance disconnect box](#)
- [Filter bag](#) or [JetFilter](#) for vent pipe
- [Turntable](#), [cart mounting](#), [BagDumper](#)
- Pressure compensation for the [outlet](#) and [feeder hopper](#)
- Cleaning and refill systems upon request