



Screw Feeder

DSR28 2.0 (DC-Smart)

Volumetric and Gravimetric



General Information

The [DSR28](#) is a feeder ideal for poor or difficult flowing bulk ingredients at low feed rates. The feeder has the following main components: a stainless steel screw trough, an agitator in the screw trough, a screw, a screw tube, a [DC smart motor](#) and an extension hopper with a volume of 5 dm³ (0.18 cuft), 10 dm³ (0.35 cuft) or 20 dm³ (0.71 cuft), low mounting height. The smart motor is characterised by an extremely high adjustment range of 1:100.

The horizontal agitator works to consistently fill the screw and prevents hopper bridging while providing mass flow. This results in optimal feeder accuracy and control.

The [DSR28](#) is easily disassembled for wet or dry cleaning by releasing three quick release clamps from the gear motor assembly. All service is from the front or rear.

The gravimetric version includes the weighing systems [MD2 and MD3](#) featuring a high-resolution digital load cell with serial data transmission as well as MS2 and MS3, with strain gauge load cell with advanced filtering technology.

The unit conforms to CE directives.

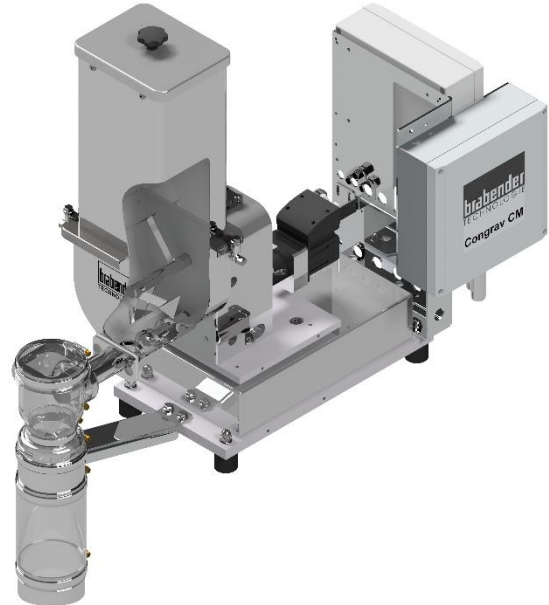

Model Specification

Screw drive	Brushless DC motor
Drive power	0.18 kW (0.24 HP)
Screw speed	268 min ⁻¹
Optional Screw speed	- *
Trough agitator	Yes
Separate agitator drive	no
* not necessary, due to extremely high adjustment range of 1:100	

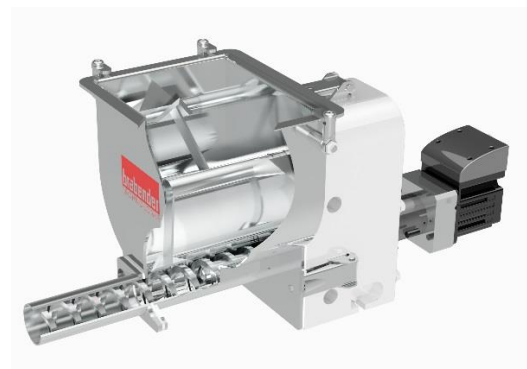

Control Modules

Control and speed modules are offered either mounted onto the feeder ([Congrav® CM-E](#)) or are available for mounting in a separate control panel ([Congrav® CB-E](#) or [Congrav® CB-S](#)).

Controls can communicate directly to most host/ PLC systems or to Brabender Technologie Congrav® Operator Interfaces.

Technical Drawings and Dimensions

	volumetric feeders	gravimetric feeders	
		Control module CB	Control module CM
5 dm ³ (0.18 cuft) Hopper	DSR28 2.0 -5Q	DDW-MD(S)2(3)-DSR28 2.0 -5Q	DDW-MD(S)2(3)-DSR28 2.0 -5Q CM
10 dm ³ (0.35 cuft) Hopper	DSR28 2.0 -10Q	DDW-MD(S)2(3)-DSR28 2.0 -10Q	DDW-MD(S)2(3)-DSR28 2.0 -10Q CM
20 dm ³ (0.71 cuft) Hopper	DSR28 2.0 -20	DDW-MD(S)2(3)-DSR28 2.0 -20	DDW-MD(S)2(3)-DSR28 2.0 -20 CM



Screw Feeder

DSR28 2.0 (DC-Smart)

Volumetric and Gravimetric



Available Screw Sizes and Feed Rates

Screw type	Designation \emptyset / p [mm]	Tube designation	Tube dia. [mm]	Max. speed [min ⁻¹]	Max. feed rate* [dm ³ /h]	Max. feed rate* [cuft ³ /hr]	Control range Screw drive
Spiral screw (S) (TA= with trough activation)	S 13/10 (TA)	160	20.0x2.0	268	17	0.6	1:100
	S 13/15 (TA)	160	20.0x2.0	268	27	1	1:100
	S 20/15 (TA)	210	25.0x2.0	268	56	2	1:100
	S 20/19 (TA)	210	25.0x2.0	268	76	2.7	1:100
	S 20/24 (TA)	210	25.0x2.0	268	100	3.5	1:100
	S 28/22	320	38.0x3.0	268	187	6.6	1:100
	S 28/35	320	38.0x3.0	268	314	11.1	1:100
Spiral screw (S) for granules	S 13/10	210	25.0x2.0	268	32	1.1	1:100
	S 13/15	210	25.0x2.0	268	50	1.8	1:100
	S 20/15	320	38.0x3.0	268	108	3.8	1:100
	S 20/19	320	38.0x3.0	268	142	5	1:100
	S 20/24	320	38.0x3.0	268	184	6.5	1:100
	S 24/35	320	38.0x3.0	268	319	11.3	1:100

* Theoretical values at 100% screw filling level and motor speed. Depending on the flow characteristics the screw filling level may decrease to 50%.

Further limitations must be considered for gravimetric feeding as max. speed should be reduced to allow for bulk density variations. The values in brackets refer to optional motors. [How to read the table of screws](#)

Technical Specification

Ambient temperature:	0°C to +45°C (32°F to 113°F)
Humidity of the air:	up to 85% without condensation
max. vacuum/pressure:	3 hPa (3 mbar) (1.2 inches of water)
Ingredient temperature:	0°C to + 60°C (32°F to 140°F)
max. bulk density (volumetric):	1.5 kg/dm ³ * (94 lb/cuft)
max. bulk density (with MD2 15/9):	1.5 kg/dm ³ (94 lb/cuft) * with hopper 5 dm ³ (0.18 cuft); 1.2 kg/dm ³ (75 lb/cuft) * with hopper 10 dm ³ (0.35 cuft)
max. bulk density (with MD2 15/15):	0.7 kg/dm ³ (43,7 lb/cuft) * with hopper 20 dm ³ (0.71 cuft)
max. bulk density (with MD3):	1.5 kg/dm ³ (94 lb/cuft) * with hopper 20 dm ³ (0.71 cuft)
max. bulk density (with MS2):	1.5 kg/dm ³ (94 lb/cuft) * with hopper 5 dm ³ (0.18 cuft); 1.5 kg/dm ³ (94 lb/cuft) * with hopper 10 dm ³ (0.35 cuft)
max. bulk density (with MS3):	0.8 kg/dm ³ (50 lb/cuft) * with hopper 20 dm ³ (0.71 cuft)
max. bulk density (with MS3):	1.5 kg/dm ³ (94 lb/cuft) * with hopper 20 dm ³ (0.71 cuft)
Screw trough, extension hopper, hopper lid:	1.4301 (304SS)
Screws, screw tubes, outlets:	1.4571 (316 SS), 1.4301 (304SS) or polyurethane, food-proof acc. to LMBG*
Non-contact components:	Aluminum, plated or painted steel (RAL 7035)
Extension hopper 5 dm ³ (0.18 cuft), 10 dm ³ (0.35 cuft) or 20 dm ³ (0.71 cuft):	Hopper lid for automatic refilling or manual refilling
Drive:	0.18 kW (0.24 HP), IP65
Power supply:	100-240 V , 50-60 Hz (1/N/PE AC) **
Net weighing range MD2 15/9:	13.5 kg (29.92 lb) with hopper 5 dm ³ (0.18 cuft); 12.5 kg (25.3 lb) with hopper 10 dm ³ (0.35 cuft)
Net weighing range MD2 15/15:	14.0 kg (31 lb) with hopper 20 dm ³ (0.71 cuft)
Net weighing range MD3:	29.0 kg (64 lb) with hopper 20 dm ³ (0.71 cuft)
Net weighing range MS2:	18.0 kg (40 lb) with hopper 5 dm ³ (0.18 cuft);
	17.5 kg (38.6 lb) with hopper 10 dm ³ (0.35 cuft)
	14.0 kg (31 lb) with hopper 20 dm ³ (0.71 cuft)
Net weighing range MS3:	34.0 kg (75 lb) with hopper 20 dm ³ (0.71 cuft)
* other values upon request	** for the operation in TT networks, TN networks or networks with earthed neutral. For different networks adaptation measures are necessary.

Options and Accessories

- Flexible [inlet and vent connections](#)
- Flexible [outlet connections](#)
- Interchangeable screws and screw tubes
- [DESTACO clamp fasteners](#) with safety switch
- Versions for higher or lower temperatures
- Explosion-proof versions as per directive 2014/34/EU, (ATEX II 2D/-- Ex h IIIB T150°C Db/--)
- Vertical outlet with [quick release](#)
- [Maintenance disconnect box](#)
- [Filter bag](#) or [JetFilter](#) for vent pipe
- [Inertia base](#), [turntable](#) or [cart mounting](#)
- [Pressure compensation for the outlet](#) Cleaning and refill systems upon request