

## Brabender Flat Slide Gate Valves

Brabender flat slide gate valves with double acting pneumatic cylinders are mainly used as automatic refill valves for loss-in-weight feeders where they release the ingredient for feeder refilling and shut off the ingredient flow again at the end of the refill phase. Their rapid opening and closing features make them particularly suitable for this task.

Of course the slide valves can also be used for any other application requiring reliable and quick release and stopping of bulk ingredient flow.

Depending on the required flow volume and the pipe diameters used, Brabender flat slide gate valves are available with diameters from 65 to 400 mm (2.6 to 15.7 in). Upon request, further diameters can be supplied.

All slide valves are fully assembled including a 5/2 way solenoid valve.

Ingredient contact surfaces are made of stainless steel.

The standard versions of the slide valves are supplied with holes drilled as per DIN EN 1092 for mounting between flanges provided by the customer.

For flexible connection to downstream and/or upstream equipment with flexible sleeves a version is available with a flanged inlet or outlet.

For applications where bulk ingredient flow is to be shut off manually, a hand wheel version is optionally available.

Brabender flat slide gate valves conform to CE directives.

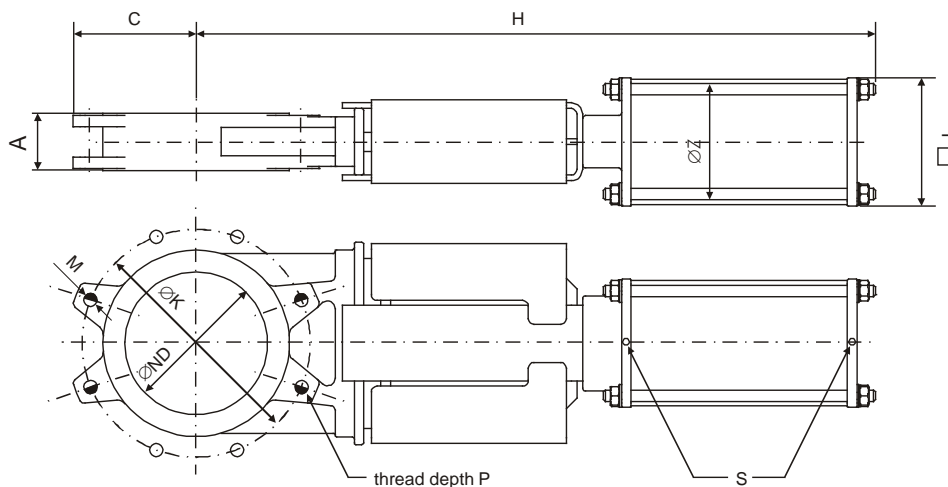
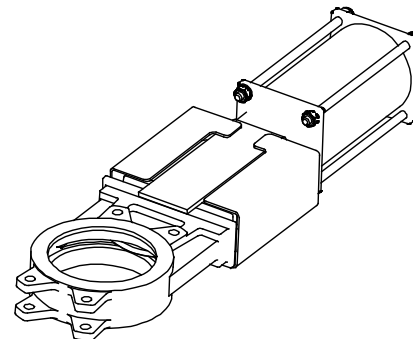

ND	A	C	Z	S	J	H	K	M	P	Threads $\odot$	Holes O	Weight
65 (2.56)	40 (1.57)	70 (2.76)	80 (3.15)	1/4 "	96 (3.78)	452 (17.80)	145 (5.71)	M16	8 (0.31)	4	0	10.0 kg (22.0 lb)
80 (3.15)	50 (1.97)	92 (3.62)	80 (3.15)	1/4 "	96 (3.78)	494 (19.45)	160 (6.30)	M16	9 (0.35)	4	0	11.0 kg (24.3 lb)
100 (3.94)	50 (1.97)	105 (4.13)	100 (3.94)	1/4 "	115 (4.53)	557 (21.93)	180 (7.09)	M16	9 (0.35)	4	4	13.0 kg (28.7 lb)
150 (5.91)	60 (2.36)	130 (5.12)	125 (4.92)	1/4 "	138 (5.43)	711 (28.00)	240 (9.45)	M20	10 (0.39)	4	4	23.0 kg (50.7 lb)
200 (7.87)	60 (2.36)	160 (6.30)	160 (6.30)	1/2 "	175 (6.89)	871 (34.29)	295 (11.61)	M20	10 (0.39)	4	4	40.0 kg (88.2 lb)
250 (9.84)	70 (2.76)	198 (7.80)	200 (7.87)	1/2 "	218 (8.58)	1027 (40.43)	350 (13.78)	M20	12 (0.47)	6	6	57.0 kg (125.7)
300 (11.81)	70 (2.76)	234 (9.21)	200 (7.87)	1/2 "	218 (8.58)	1177 (46.34)	400 (15.75)	M20	12 (0.47)	6	6	68.0 kg (149.9 lb)
350 (13.78)	96 (3.78)	256 (10.08)	250 (9.84)	1/2 "	270 (10.63)	1380 (54.33)	460 (18.11)	M20	21 (0.83)	8	4	129.0 kg (284.4 lb)
400 (15.75)	100 (3.94)	292 (11.50)	250 (9.84)	1/2 "	270 (10.63)	1536 (60.47)	515 (20.28)	M24	21 (0.83)	10	6	152.0 kg (335.1 lb)

Dimensions in mm (in)

# Technical Data

## Components

- Valve housing
- Slide plate
- Housing covers
- Double acting pneumatic cylinders
- 5/2 way solenoid valve
- Sound muffler
- Screw fittings with piping

## Flow Rates

Max. theoretical flow rate*	
Diameter mm (in)	Flow rate approx. dm <sup>3</sup> /s (ft <sup>3</sup> /s)
65 (2.56)	1.5 (0.05)
80 (3.15)	3.0 (0.11)
100 (3.94)	5.0 (0.18)
150 (5.91)	15.0 (0.53)
200 (7.87)	30.0 (1.06)
250 (9.84)	50.0 (1.77)
300 (11.81)	80.0 (2.83)
350 (13.78)	120.0 (4.24)
400 (15.75)	160.0 (5.65)

- \* All data are theoretical values referring to free flowing bulk ingredients. Depending on the flow characteristics and granulometry of the respective ingredient, the actual maximum flow rate may be up to 80% less!

## Materials

- Housing: cast stainless steel CF8M ≈ SS 1.4408 (316 SS)
- Slide plate: stainless steel SS 1.4401 (316)
- Housing covers: mild steel, painted black
- Sealing between slide plate and housing: silicone (soft seal)
- Stuffing box sealing: cotton, PTFE impregnated

## Operating Temperature

- Max. bulk ingredient temperature: +120°C (+248°F)

## Pneumatic Drive

- Double acting pneumatic cylinders
- 5/2 way solenoid valve and operating magnet with recovery diode
- Operating pressure: 6-8 bar
- Supply voltage: 24 VDC or 230 VAC

## Mounting

- Standard version:
  - Slide valve holes drilled as per DIN EN 1092, PN10
  - Mounting position between connection flanges on site

## Accessories/Options

- 2 limit switches (3 wires)
- Solenoid valve and limit switches wired to a junction box (additional weight 2.5 kg ≈ 5.5 lb per slide valve)
- Flanged inlet and/or outlet, 50 mm (2.0 in) high, gasket included, for flexible connection to downstream and/or upstream equipment
- Flexible connection sleeves
- Anti-wear cone for coarse-grained bulk materials and fibers
- Alternative sealing materials (please contact us for information on usable sealing materials)
- Explosion proof design
- Slide valve version with hand wheel for manual operation
- Slide valve version with single acting pneumatic drive, spring loaded (safety position = "Closed")

## Application Examples

- Automatic refill valve for Brabender loss-in-weight feeders
- Automatic refill valve for volumetric metering feeders with level sensors
- Automatic refill valve for intermediate storage hoppers with level sensors
- Outlet valve for Brabender BAV bin activator

Slide valve design not available in North America. For North American version see separate Works Standard.



Modifications reserved. All data describe our products in a general manner. They are no agreement on or warranty of characteristics in the sense of § 434 or guarantee in the sense of § 443 of the German Civil Code or similar regulations and effect no liability.

Issue 4.0 (April 16)  
Supersedes 8.0 (August 13)